



## Installation Instructions



**Tools Needed:** 7/16" Wrench or Adjustable Wrench  
3/16" Allen Wrench (included with Trip Mechanism)  
1/8" Allen Wrench (included with Trip Mechanism)

**Materials Recommended:** Tie-Line

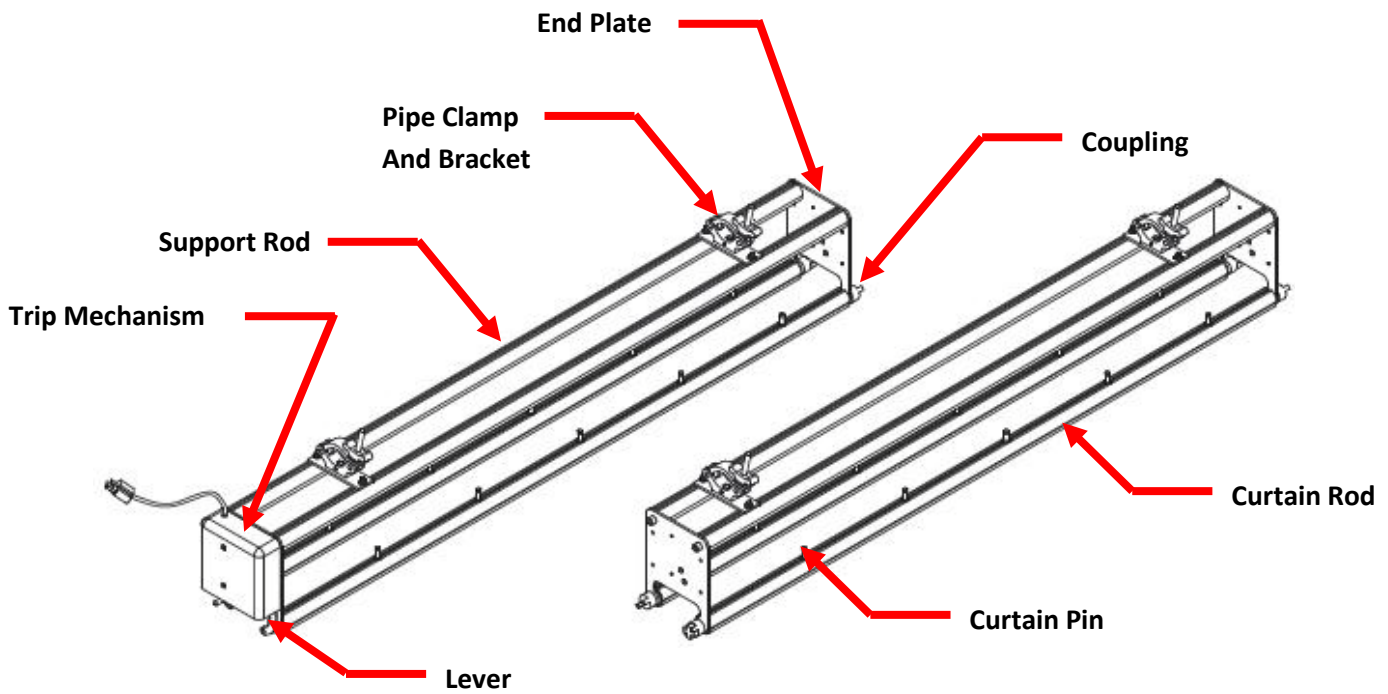

Figure 1: Kabuki units with and without a Trip Mechanism installed.

**Step 1:** Layout all Kabuki units on the floor below batten pipe or truss. Units with **trip mechanisms** indicated by a plastic cover go on the ends with the plastic cover facing off-stage (If **trip mechanisms** are not installed, see **Trip Mechanism** instructions). Loosen **thumb screws** on all **pipe clamps** completely. You may also need to loosen the **pipe clamp bracket nuts** slightly (just enough so they slide) using a 7/16" wrench.



Figure 2

**Step 2:** Starting from the center of the batten pipe or truss, hang one Kabuki unit (aligned with center) and tighten the **pipe clamp thumb screws** and **bracket bolts**.

**Step 3:** Hang another Kabuki unit adjacent to the first and tighten the **pipe clamp thumb screws** only.

**Step 4:** Align **curtain pins** on **curtain rods** with one another (i.e. all pointing up) and push units together so the **couplings** are completely meshed, keeping **curtain pins** in alignment (refer to Figure 3). The **couplings** are preset at the factory and should not need adjusting, but if the **curtain pins** are out of alignment, adjust the angle by loosening the set screw on one side of the **coupling** with an Allen wrench (included); rotate the **curtain rod** so the **curtain pins** are in alignment and retighten the set screw. **You MUST make sure all set screws are tight before operating Kabuki units.**

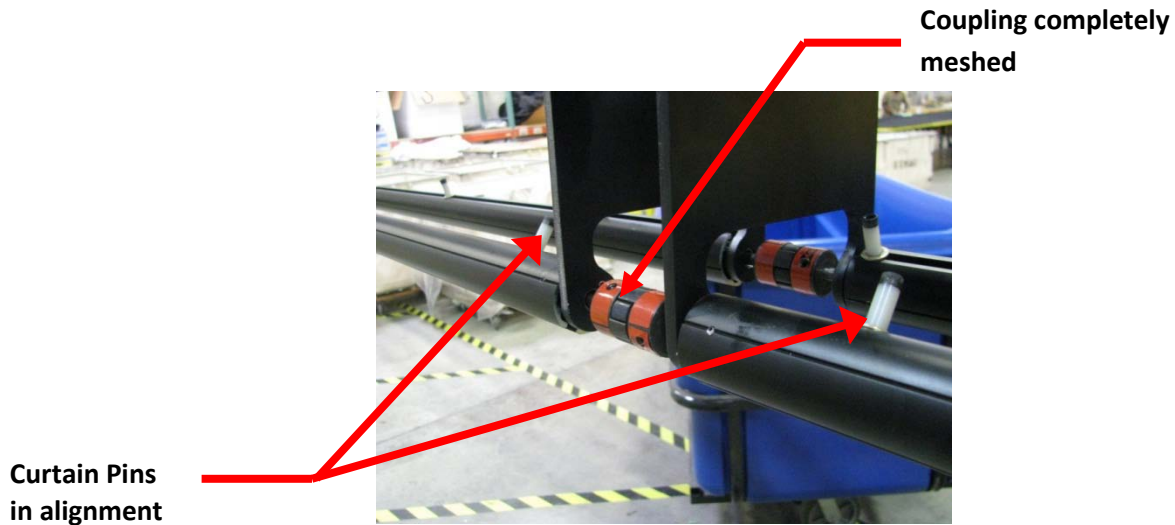

Figure 3

**Step 5:** Once the units are meshed together tighten the **pipe clamp bracket nuts** (refer to Figure 2).

**Step 6:** Repeat steps 3, 4, and 5 until all units are in place.

**Step 7:** Rotate **curtain rods** so the **lever** on the end engages and is prevented from rotating. Make sure the **counterweight** (sandbag) and manual release are hanging straight down and unobstructed (refer to Figure 4).

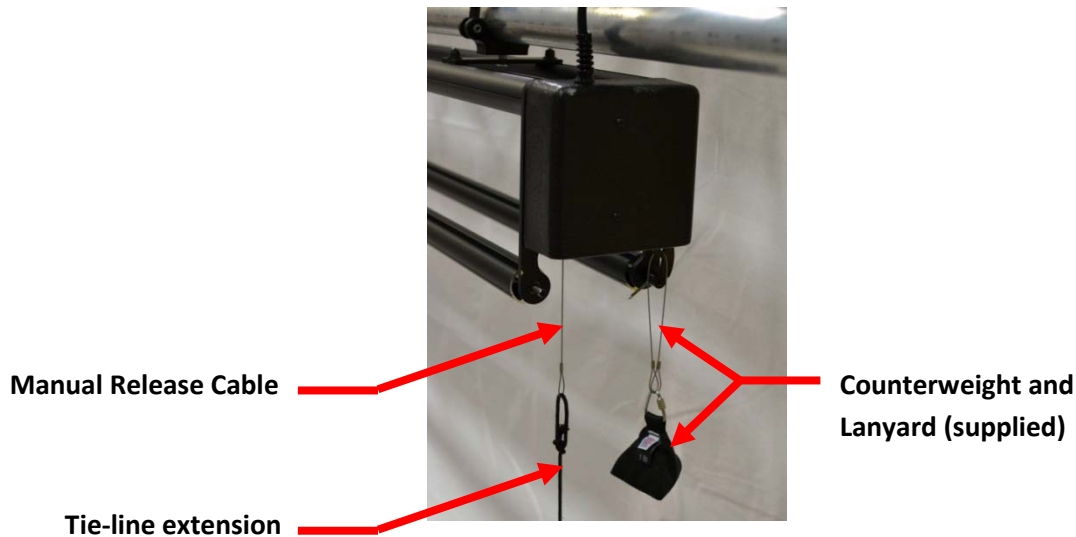

Figure 4

**Step 8:** If you are using a manual release as your primary method, ensure the tie-line is securely tied to each manual release cable. When using an electric release, plug the **trip mechanisms** into a light board or the **pendant control** unit. (When using extension cords make sure to properly secure the connections with tie-line or gaffer's tape ensuring they will not separate. The extension cord(s) should also be supported by securing them to the batten, truss or **support rods** of the Kabuki units every few feet or as necessary).

**Step 9:** Test the units noting which tie-line, channel or button triggers the upstage and downstage **curtain rods**. (This is especially important for a Double Kabuki because the Kabuki bag needs to be triggered first while the curtain needs to be triggered second; refer to **Double Kabuki** Instructions).

**Step 10:** Re-engage the Kabuki **curtain rod(s)** into their respective latches, again making sure the **counterweight** (sandbag) and manual release are hanging straight down and unobstructed (refer to Figure 4).

**Step 11:** Hang the main curtain. Starting at the center of the layout, place the center grommet of the curtain over the centermost **curtain pin**. Continue out to each end, placing each **curtain pin** along the **curtain rod** as needed for each grommet.

**Helpful Hint:** It is important to be familiar with the Kabuki units so test the functionality of the units often and before going "live". Also, ensure that the curtain will be the only thing falling from above. Please remember **SAFETY FIRST!**

## If Double Kabuki Drop is required...

**Step 1:** In order to conceal the Kabuki mechanism with the Kabuki bag attach Kabuki bag to the outside of the downstage **support rod** and allow it to hang.

**Step 2:** West Coast (bunch) main curtain and bring the bottom edge of the Kabuki bag up and attach to the upstage **curtain rod** as you did with the main curtain (refer to Figure 5).

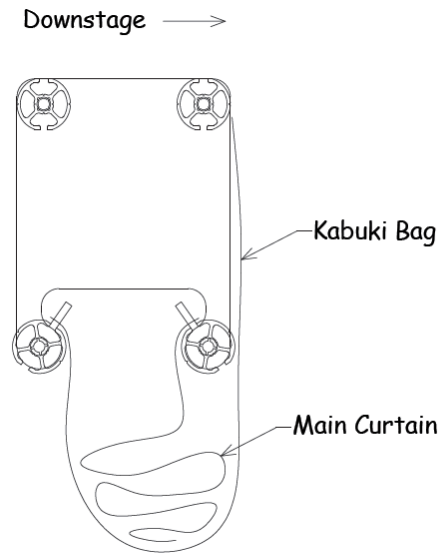

Figure 5

**Helpful Hint:** A Double Kabuki Drop will require two **trip mechanisms**. These can be controlled by the **handheld pendant**, a light board or by using the manual release lines. In the case of the manual release lines however, there will be two lines, one on each side of the stage (stage right and stage left). Make sure they are labeled and everyone is aware of their function and which line gets pulled first.

## Install Trip Mechanism

Included with Trip Mechanism: Trip Mechanism, Mounting Bolts and Washers, Lever, Cotter Pin, Counterweight, Mounting Lanyard, 1/8" L-Hex Key and 3/16" L-Hex Key

**Step 1:** Remove the **couplings** from one side of a Kabuki unit to prep it for the **trip mechanism**. (Do this for a second unit if a Double Kabuki is required).

**Step 2:** Bolt the **trip mechanism** to the **end plate** of the Kabuki unit(s) using the four (4) bolts and washers provided.

**Step 3:** Slide the **lever** onto the **shaft** on the right side and align it with the **curtain pins** on the **curtain rod** and pin it into place using the **cotter pin** provided.

**Step 4:** Install the **counterweight** by threading the **lanyard** provided through the hole in middle of the **lever** and hooking the **counterweight's** quick-link onto both loop ends. Close the quick-link by tightening the nut and allow the **counterweight** to hang down unobstructed.

**Step 5:** Tie a length of tie-line to the cable protruding from the plastic cover. The length of this cord should be as long as the curtain is tall. This is your manual release. In the event of an electrical failure, simply pull this cord and the curtain will release.

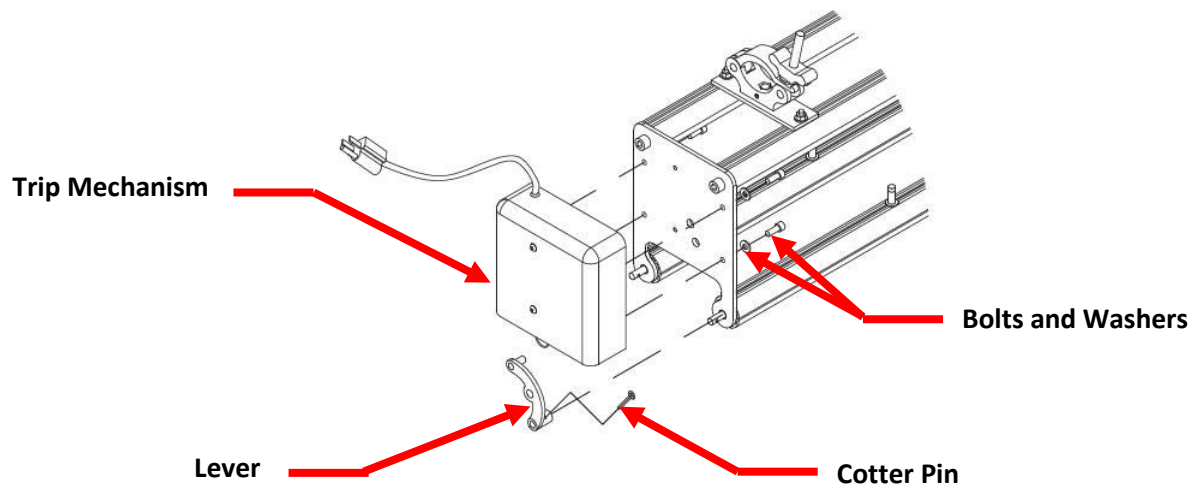

Figure 6

## Pendant Controller

**Step 1:** Clamp the **electrical box** included with the **pendant controller** to the batten pipe or truss next to the Kabuki units. It is best to place this box off-stage and use extension cords as necessary.

**Step 2:** Plug in the Kabuki **trip mechanism(s)** to the **electrical box**. The **pendant controller** gets attached to the **electrical box** by the control outlet on the bottom right-hand side. Then plug in the **electrical box** itself.

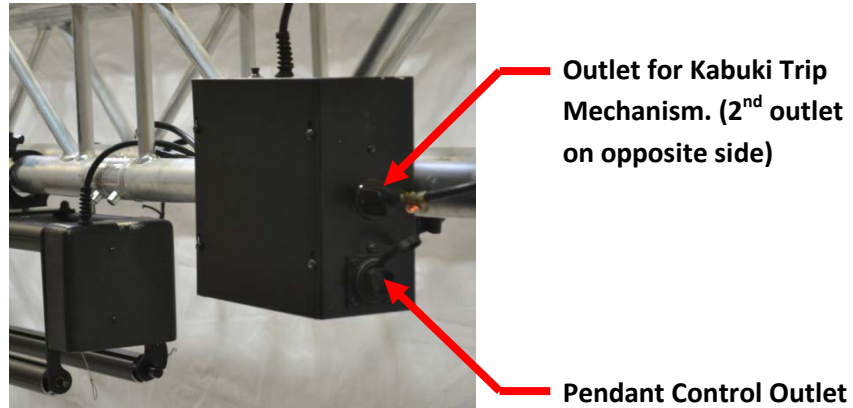

Figure 7

**Helpful Hints:** The “Power” light on the **Handheld Pendant** will illuminate when power is supplied (this only means the electrical box and pendant have power; it does not mean the trip mechanisms are plugged in). When the “Arm” toggle switches are down the units cannot be triggered. To activate the unit push the desired toggle switch up. To trigger the unit press the corresponding “fire” button.

With toggle “Arm” switch up; press “Fire” button to trigger Kabuki



When Power Light is lit, Pendant has power.

Figure 8