

Distributed by

 **ROSE BRAND**

NY (800) 223 – 1624

CA (800) 360 – 5056

[www.rosebrand.com](http://www.rosebrand.com)

**wahlberg**

MOTION DESIGN

Jaegergaardsgade 160

DK-8000 Aarhus C

DENMARK

WWW.WAHLBERG.DK

## 220 Winch 25

# User Manual



## Index:

<b>GENERAL</b>	<b>3</b>
<b>PRODUCT CONTENT</b>	<b>4</b>
<b>DESCRIPTION</b>	<b>4</b>
<b>AREA OF USE</b>	<b>4</b>
<b>WINCH 25 FEATURES</b>	<b>6</b>
<b>CONNECTING THE WINCH</b>	<b>7</b>
<b>ADJUSTING THE LIMIT SWITCHES</b>	<b>8</b>
<b>MENU</b>	<b>11</b>
<b>LIFTING CAPACITY AND REQUIRED SETTINGS</b>	FEJL! BOGMÆRKE ER IKKE DEFINERET.
<b>CONTINUOUS USE</b>	FEJL! BOGMÆRKE ER IKKE DEFINERET.
<b>LED FUNCTIONS</b>	<b>15</b>
<b>ERRORS AND ERROR CODES:</b>	<b>15</b>
<b>POWER FAILURE</b>	<b>15</b>
<b>INSPECTIONS AND MAINTENANCE</b>	<b>16</b>
<b>MAINTENANCE PLAN</b>	<b>16</b>
<b>ROLLING UP THE WIRE</b>	<b>17</b>
<b>CHEAT SHEET - WINCH 25</b>	<b>18</b>

## TECHNICAL SPECIFICATIONS:

Item No.	: 220
Dimensions	: 400 x 225 x 290 mm / 15.74 x 8.86 x 11.42 in (Height-Width-Depth)
Power supply	: 230 volt AC 50 - 60Hz.
Power consumption	: Max 300 Watt.
Power plug	: Neutrik powerCON male
DMX Control signal	: DMX 512 1990 + DMX 512A / 6 Channels used
DMX connection	: 5 pole XLR, In & link
Lifting height	: 10 m. (33 ft.)
Lifting capacity	: 25 kg. (55 lbs.)
Lifting speed	: Variable 5-40cm/s (2-15.7in/s)
Lifting cable	: 2mm galvanised steel wire, 8mm snap hook, MBL 281 kg (620 lbs.)
Min. Load	: 1 kg. Lower weight can cause wire winding problems.
Wire Fleet	: 85mm (3.3 in)
Ambient temperature	: 0-40 °C (32- 104 °F)
Duty cycle	: Max 30% at max load
Noise emission	: ~50 dB
Weight	: 21 kg. (46 lbs.)
Mounting clamp	: Slim eye coupler (Max load: 300 kg) Two couplers separated by 202mm (7.88 in)
Motor	: 230 V AC, 0.25 kW, IP55

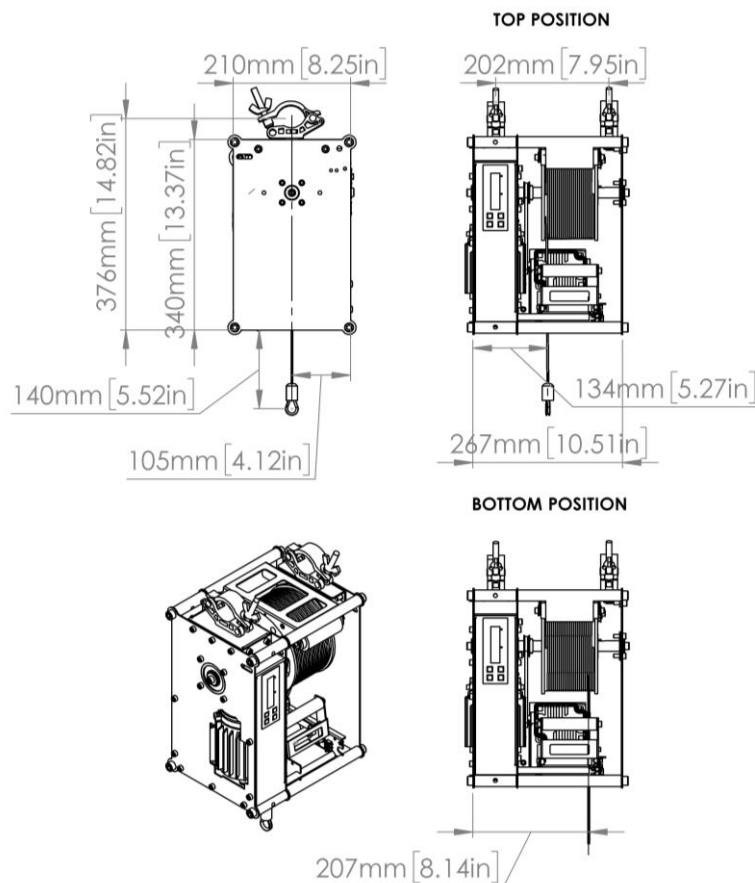

## General

Before using the winch for the first time, please read the installation- safety- operation- and maintenance instructions carefully. Failure in handling can cause injury of persons and/or damage the winch.

### Product content

1 Winch 25  
1 Powercon plug for cable  
1 Instruction manual

### Description

The Winch25 is a wire winch for lifting and moving scene objects.

The winch is controlled from the lighting desk, and thereby stage movements can be controlled in corporation with the lights, this will add dynamic to the performance or play.

Winch25 has an advanced positioning system that is controlled with a 16 bit DMX channel.

This gives a very high accuracy.

The lifting speed is also controlled by DMX, and it is possible to limit the outer ranges of how high or low the winch can move.

Winch 25 should only be operated by an experienced DMX-controlled-lighting-desk-operator.

The lighting desk has to be programmed according to the manual, so the winch will stop when the speed is put to 0 %. It is also possible for the user to stop the winch on the main.

After power failure the start position of the winch should be reset.

*The winch is for indoor use only!*

### Area of use:

The Winch is intended for indoor use. It is designed for lifting and lowering material at the weight and speed stated in "Technical Data". Any other use of the winch may result in a risk of injury of persons or equipment damage.

Exceeding the load rating may cause failure of the equipment.

Use only approved rigging connectors to secure the load to the wire and do not wrap the wire around the load as this will damage the wire and result in a risk of injury of persons or equipment damage.

Do not modify the winch. Any modification you might need should be done by Wahlberg.

It is the customers' responsibility that any local restrictions concerning the use of the winch are complied with.

**Caution:** "To reduce the risk of electric shock or injury: Use Indoors Only."

**Caution:** "To reduce the risk of electric shock, do not expose to rain: Store indoors."

**Attention!**

*Before running the winch read the user's manual paying special attention to the chapter "Connecting the winch".*

*It is important to keep the wire in a good condition. See "Maintenance".*

***Make sure the operator is able to watch the winch while running it in order to have visual confirmation of the movements.***

*The winch should only be operated by an experienced DMX-controlled-lighting-desk-operator.*

When running manually, the operator should make sure not to be placed in a hazardous situation. Likewise it is the operator's responsibility not to run the winch in a way that brings other persons in a hazardous situation.

During set-up and each time before use, the safe condition of the winch must be established with a visual inspection and a functionality test.

Pay special attention to the mounting of the winch and the condition of the wire!

**Cautions at power failure:**

The winch will stop at power failure. When the power is re-established, the winch has to be reset before it is ready to use.

It is advisable to set all the DMX channels on 0 % before the power is re-established.

**Warning!**

*Use of the winch for other than the intended purpose can cause injury!*

## **Winch 25 Features**

The Winch25 is a wire winch for lifting and moving scene objects.

The winch is controlled from the lighting desk, and thereby stage movements can be controlled in corporation with the lights, this will add dynamic to the performance or play.

Winch25 has an advanced positioning system that is controlled with a 16 bit DMX channel.

This gives a very high accuracy.

The lifting speed is also controlled by DMX, and it is possible to limit the outer ranges of how high or low the winch can move.

Before the Winch is powered down channel 4 should be set outside the enable area. When it is set outside this area the current position is saved and when it is powered up no resetting of positions is needed. If this isn't done the top position has to be reset using channel 5.

When the Winch25 is turned on the winch cannot run before DMX channel 4 has been out of the enable area of 50-55 %, after this the winch has to be reset again.

### **Counterweight:**

It is very important to have at least 1Kg load on the wire before start running the winch. If no weight is applied in the wire, it will jam on the drum.

### **DMX channels used for controlling the winch**

(For a more detailed description see page 9)

DMX channel 1 – Position. (16 bit DMX channel)

DMX channel 2 – Position fine. (16 bit DMX channel)

DMX channel 3 – Maximum speed

DMX channel 4 – Motor Enable – between 50 % and 55 %, to enable the motor output.

DMX channel 5 – Reset UP

DMX channel 6 – Manual DWN, (Sets the TAC RANGE)

### **Resetting the up position:**

**Channel 5 needs to be active for ~3s before the winch will start resetting.**

Run the motor to the top reset position, with channel 5.

Setting DMX channel 5 to 0% resets the top position

## Connecting the Winch

### Power supply

The Winch 25 must be connected to 208-240VAC,

Power is connected to the blue Neutric Powercon connector.

By supplying power to the winch, the display will show a start-up screen and then change to

DMX CONTROL  
START CHAN 1

### DMX

DMX is connected to the male 5-pole XLR connector.

The DMX LED will light constantly when receiving a DMX signal, and it will blink when no DMX are received.

### Ready to use

When the winch has been connected to 230VAC and a DMX light desk it is ready for use, and can be controlled from the light desk.

## Adjusting the limit switches

To adjust the limits first remove the black cover, it is attached with two screws.

The limit switch determines the maximum and minimum travel distance of the winch.

To adjust the limit switch loosen the middle screw. Then the top and bottom limits can be adjusted with the two screws. The limits are adjusted by rotating the white levers using the screws for top and bottom limit. While adjusting the limits put the winch in manual mode. The winch will write out LIMIT TOP ACT when it hits the top limit while moving up and LIMIT BOTTOM when it hits the bottom limit going down. When adjusting a click can be heard when the switch is pressed or released.

When adjustments are done make sure to tighten the centre screw again!

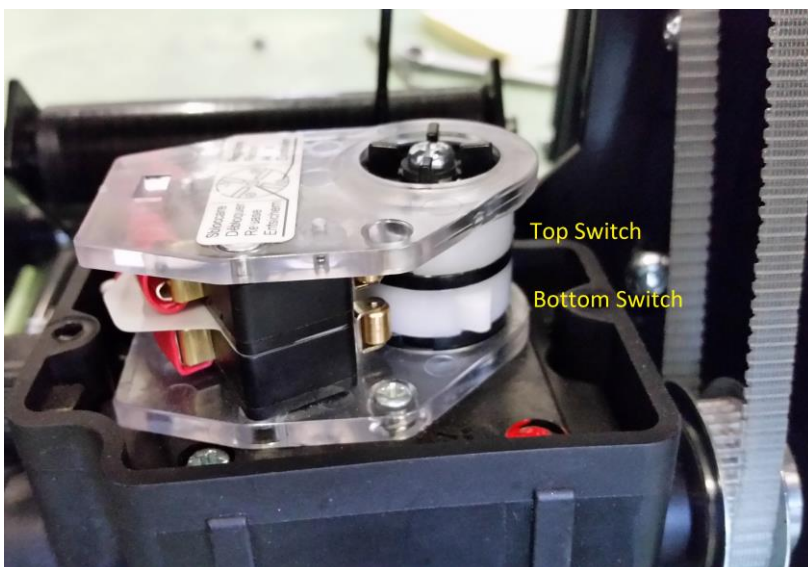
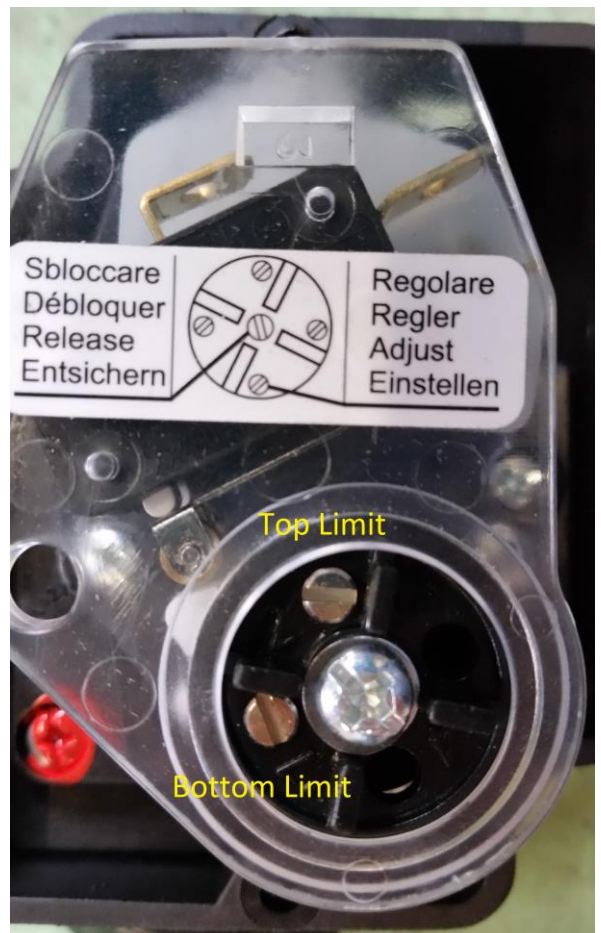
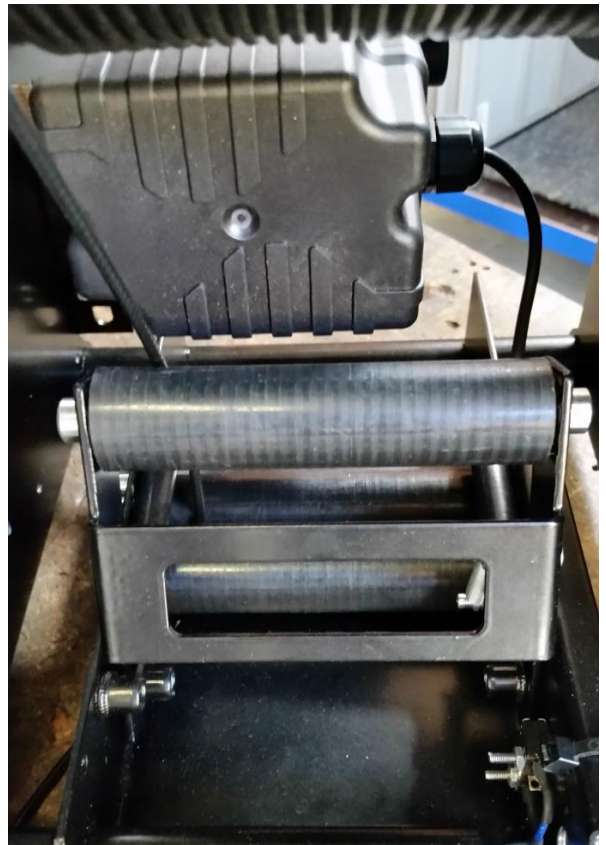



## Emergency stop switch (Optional)

The Winch can be configured with an emergency stop

**By default the emergency stop is NOT enabled!**

If the emergency stop switch is activated (pin 1 and pin 4 are disconnected) the red ERROR LED will light.

The emergency stop switch is connected to the male 4 pole XLR connector.

Pin 1 and Pin 4 should be powered with 12-15 volt DC to enable the running of the motor

Pin out:

Pin 1 = GND

Pin 2 = NC

Pin 3 = NC

Pin 4 = 12 – 15 volt DC

Ready to use

When the Rolldown has been connected to power, DMX, and an emergency stop switch, it is ready for use, and can be controlled from the lighting desk.



## Enable Emergency stop

To enable to emergency stop 2 steps are required. First in the menu change E STOP to ON. Secondly inside the unit there is an orange wire that needs to be set correctly for operation with/without emergency stop.

**Emergency stop disabled**



**Emergency stop enabled**



When the emergency stop is enabled and the little piece of orange wire is not connected it is recommended that it is secured in some way so it does not hit anything. Some electrical tape will be enough to keep it in place.

## **DMX Control**

When the Winch 25 is connected to the power supply and a DMX light-desk it is ready for use and can be controlled from the light-desk.

### **DMX channel description**

DMX channel 1 – Position. (16 bit DMX channel)

DMX channel 2 – Position fine. (16 bit DMX channel)

DMX channel 3 – Maximum speed

DMX channel 4 – Motor Enable – between 50 % and 55 %, to enable the motor output.

DMX channel 5 – Reset UP

DMX channel 6 – Manual DWN

### **DMX channel 1 – Position. (16 bit DMX channel)**

This channel, together with channel 2, makes up a 16 bit position on the winch.

A high value on channel 1 gives a high position. A low value on channel 1 gives a low position on the motor.

### **DMX channel 2 – Position fine. (16 bit DMX channel)**

This is the fine position of the winch. This channel, together with channel 1, makes up a 16 bit position on the motor.

Channel 2 is used to fine-tune the position.

### **DMX channel 3 – Speed**

Channel 3 is used to control the speed or the maximum speed of the winch.

If channel 3 is 0% the motor will not run.

If channel 3 is 50% the motor will run at 50% speed.

### **DMX channel 4 – Motor Enable 50 % and 55 %, for the motor to turn.**

Channel 4 is used as an extra security channel.

The value on channel 4 needs to be between 50 and 55 %, for the motor to run.

All other values make the motor stop.

All other values will also reset any error shown.

All other values will save the current position before a power down.

### **DMX channel 5 – Reset Up**

There is a 3s delay on this channel to reduce risk of accidentally resetting the top position.

Channel 5 is used to manually move the wire up.

When channel 5 is in use it will run the motor Up until it hits the limit switch UP.

Setting DMX channel 5 to 0 resets the position.

10 – 100% makes the motor run up, at variable speed.

(10% = low speed – 100% = full speed).

### **DMX channel 6 – Manual DWN, (Sets the TAC RANGE)**

There is a 3s delay on this channel to reduce risk of accidentally setting a new range

Channel 6 is used to manual move the wire down.

When channel 6 is in use, it runs the motor down, until the limit switch DOWN is reached.

The position is reset and a new TAC RANGE is calculated. The new range is the tacho pulses, between top position set by channel 5 and bottom position set by channel 6.

10 – 100 % makes the motor run down, at variable speed.

(10 % = low speed – 100 % = full speed).

## MENU

The menu structure is divided into two different areas for safer motor control.

### Control mode

The display shows: `DMX CONTROL`  
`START CHAN 1`

### Control mode – Expanded view

Expanded view is activated by holding the DOWN button for approx. 5 seconds.  
Here it is possible to watch the different parameters:

`P = ACTUAL POSITION`      `D = DELTA POSITION`  
`W = WANTED DMX POSITON`      `S = SPEED`

Holding the DOWN button for further 5 seconds will reveal the received DMX values in the menu. The value is shown in the menu as this:

`CH1 CH2 CH3 CH4`  
`CH5 CH6 CH7 CH8`

### Menu navigation mode

Top Line shows `MENU NAVIGATE`

In menu navigate mode, the different parameters can be changed, e.g. DMX, address, max speed etc.

In menu navigate mode the motor is stopped and DMX input has no effect, the motor can be moved by the MAN UP/DWN menu though.

### Menu mode change

*MENU - NAVIGATE:*

The top line of the display is showing:

`DMX CONTROL`

Push the buttons **UP** & **DOWN** and hold them for 3 seconds.

Now the top line of the display should show:

`MENU NAVIGATE`

*MENU - DMX CONTROL:*

Go back to the starting position and activate DMX control

The top line of the display is showing:

`MENU NAVIGATE`

Push the buttons **UP** & **DOWN** and hold them for 3 seconds.

Now the top line of the display is showing:

`DMX CONTROL`

### Navigate the menu

The top line of the display is showing:

`MENU NAVIGATE`

Push the buttons **UP** & **DOWN** to go up and down in the menu choices.

The bottom line of the display is showing:

`DMX ADDR 1`

### Adjusting menu parameters

The top line of the display is showing:

`MENU NAVIGATE`

The bottom line of the display is showing:

`DMX ADDR 1`

Push **ENT** to change the DMX ADDR value.

The top line of the display is showing:

`EDIT MENU VALUES`

The bottom line of the display is showing:

`DMX ADDR 1`

### Save changed value

The top line of the display is showing:

The bottom line of the display is showing:

Push **ENT** to change the top line to:

Press and hold **ENT**

The top line of the display counts up to 20 then shows OK.

The Value is now saved in the memory.

```
EDIT MENU VALUES
DMX ADDR      270
SAVING        1-20
```

```
SAVING      OK
```

### Adjustable parameters

		<b>Range</b>	<b>Default</b>
MAN SPEED	Speed for manual driving	200 – 1200	500
MAN UP/DOWN	Run the motor manual from the menu	MOTOR UP / MOTOR DOWN	
DMX ADDR	DMX start address	1 – 506	1
TAC RANGE	Tacho range	1 – 32000	28900
SPEED MAX	Maximum speed	500 – 3500	2800
SP MIN UP	Minimum speed UP	200 – 1000	200
SP MIN DOWN	Minimum speed DOWN	100 – 1000	200
E STOP	Enable/disable emergency stop	ON-OFF	OFF

MAN SPEED and MAN UP/DOWN are used for manual control of the motor. The motor is only running as long as the UP or DOWN arrow is pressed.

## Detailed explanation of all parameters

**MAN SPEED**                      **Speed for manual driving.**                      **Range**                      **200 – 1200**

MAN SPEED sets the speed for manual driving the motor.

1200 sets the maximum speed to 1200 RPM and 200 sets the minimum speed.

**MAN UP/DWN** **Manuel driving the motor.**

MAN UP/DWN is used for manual control of the motor.

Pressing the UP button makes the wire run up, unless the limit switch is activated.

Pressing the DOWN button makes the wire run down, unless the limit switch is activated.

**DMX ADDR**                      **DMX start address**                      **Range**                      **1 - 509**

DMX start address defines which DMX address the Winch 25 reacts on.

**TAC RANGE**                      **Tacho range**                      **Range**                      **0 – 32.000**

The tacho range is setting the maximum range of the Winch.

The tacho range can be set to higher values by manually running the winch with channel 6.

**SPEED MAX**                      **Maximum speed**                      **Range**                      **500 – 3500**

SPEED MAX sets the maximum speed.

If set to 1000, it means the motor run at 1000 RPM when DMX speed is set to full. SPEED MAX can be used to lower the maximum speed, e.g. while learning the system.

**SP MIN UP**                      **Minimum speed up.**                      **Range**                      **200 – 1000**

The motor minimum speed for the up direction:

The motor is allowed to run at different minimum speed for each direction; this is to differentiate between different mechanical loads, for up and down see SP MIN DWN.

Set this value to a speed where the motor will still run up at full load.

**SP MIN DWN**                      **Minimum speed down**                      **Range**                      **100 - 1000**

The motor minimum speed, for the down direction:

The motor is allowed to run at different minimum speed for each direction; this is to differentiate between different mechanical loads, for up and down see SP MIN UP.

Set this value to a speed where the motor will still run down at full load.

**E STOP**                      **Enable/disable emergency stop**                      **Range**                      **ON - OFF**

This enables/disables the emergency stop from the software. However to get the full functionality of the emergency stop a wire has to be plugged in inside the winch. See section on how to change the wire setting for more details.

## **Normal Operation**

### **Temperatures**

If the surface temperature of the winch exceeds 90 degrees Celsius there is a risk of damaging the winch.

### **Duty cycle**

The winch should not be operated at a duty cycle higher than 30% for longer periods of time.

### **Lifting speeds and weight**

The load of the winch impacts the minimum speed it can operate at. At high loads the minimum speed up must be increased to a point where the winch can still move.

If a lower load is used with high minimum speeds the winch might have problems with finding its position. Lower the minimum speeds if this is a problem.

The minimum speed can be adjusted from the menu.

### **Wire fleet**

Because of the way the winch rolls up the wire the place where the wire comes out of the winch changes depending on how much wire has been rolled out. The wire moves 83mm sideways from the top position to the bottom position during the movement.

## LED Functions

### DMX LED

The DMX lamp will light steady green when receiving a DMX signal.

The DMX lamp will blink green if no DMX signal is present.

### Error LED

The error LED will light red if there is an error.

Reset error is done by toggling the setting DMX channel 4 to 0.

When the Error LED lights red, there will also be an error description in the display.

## Errors and error codes:

Winch will not start, display shows nothing.	Check if the winch is connected to mains power. Check if the fuse in the winch is blown.
Winch will not start, DMX lamp is blinking.	Check DMX signal
The winch will not run, DMX LED is steady green.	Check limit switch inputs are connected. Check slack detection.
The wire is not wound up on the drum correctly.	Manually lower the wire totally of the drum, while controlling that the wire comes out of the winch nicely. Afterwards the wire is rolled back onto the drum.  Reset the top position afterwards.

## Power failure

The winch will stop at power failure. When the power is re-established, the winch has to be reset before it is ready to use.

It is advisable to set all the DMX channels on 0 % before the power is re-established.

## **Inspections and Maintenance**

*Interval of inspections should be determined according to the frequency of use and the working scenario of the winch.*

It is very important for the safety of persons and for the operation of the winch that the winch is kept in a good condition.

If the wire runs in an angle it wears down faster.

Signs of malfunction or poor operation should always lead to an inspection of the winch, and the winch should be taken out of operation until the error is eliminated.

Do not use a malfunctioning winch.

## **Maintenance plan**

### **Before every use and Weekly:**

Every time when rigging the winch, before running the winch – and at least every week when the winch is in use:

- Check the entire length of the wire rope for bends, crushed areas, broken or cut cord, corrosion and other damages.
- Check all limit switches.
- Check the slack detection device.
- Apply a thin layer of silicone to the slack detection metal drum/wirer if necessary.
- Check that the wire is wound neatly in the groove of the drum.

### **Monthly:**

At regular intervals – but at least every month when the winch is in use:

- Check the mounting clamps for damages and proper fastening.
- Check that the load is properly and secure fastened.
- Change damaged or malfunctioning parts.

### **Every 12 month:**

The winch has to be inspected by a specialist every 12 months

### **Every 48 month:**

The winch should be inspected by an authorised expert every 48 months.

The results of the regular inspections are to be documented and kept available at the company. The written result of the last inspection must be kept available at the site of operation, e.g. by an inspection sticker on the winch showing the date of the inspection, the basis of the inspection and the name of the inspector.



## Rolling up the wire

When delivered the wire has a thin layer of silicone grease on the drum / wirer.  
This silicone grease **prevents** the wire from jumping or making a creaking sound when rolling up and down.

After some days of use this silicone may have dried out, and the sound will come back.

Apply a thin layer of silicone to your finger and apply it onto the drum.

Please see pictures below:

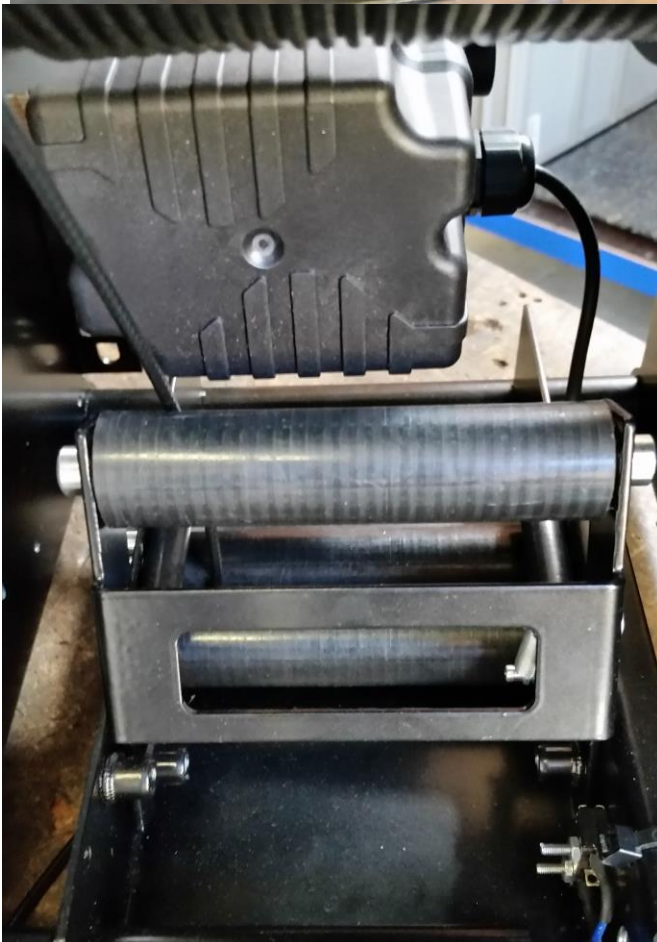
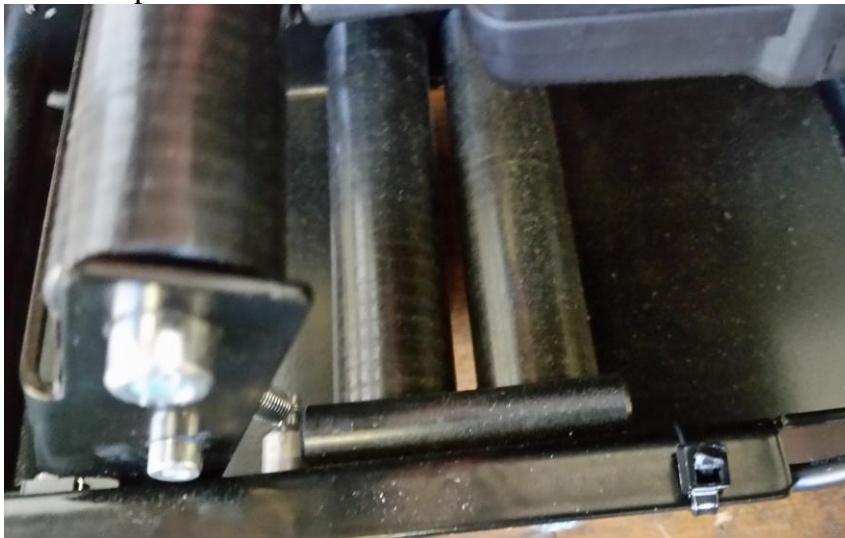

## Cheat sheet - Winch 25

### Before use

When using the Winch 25, always have a counter weight placed on the wire (Minimum 1kg)

When using the Winch 25, **make sure you can see it, so you have visual confirmation on the movements.**

The Winch 25 uses 6 DMX channels. In order to make it easier to learn how to use it: Patch out the 6 DMX channels to faders on your light desk.

### DMX channels

DMX channel 1 – Position. (16 bit DMX channel)

DMX channel 2 – Position fine. (16 bit DMX channel)

DMX channel 3 – Maximum speed

DMX channel 4 – Motor Enable – between 50 % and 55 %, to enable the motor output.

DMX channel 5 – Reset UP (~3s delay)

DMX channel 6 – Manual DWN (Sets the TAC RANGE) (~3s delay)

### Getting started

1. Hang up the winch, so there is space for the wire to move without hitting the floor.
2. Put counterweight on the wire loop, minimum 1kg.
3. Connect to 230VAC – **The display is now showing the start-up message.**
4. Set DMX channel 4 between 50 % and 55 %  
**Motor is now enabled.**
5. Set DMX channel 5 to 30 %  
**The winch now moves to its top position, set DMX channel 5 to 0 % when the winch has reached the top position.**
6. Set DMX channel 6 to 30%  
**The winch now moves to its bottom position, set DMX channel 6 to 0 % when the winch has reached the desired bottom position.**
7. Set DMX channel 1 to 100 % and DMX channel 3 to 20 %  
**The wire loop is now running to the top with 20 % speed.**
8. Set DMX channel 1 to 90% and DMX channel 3 to 50 %  
**The wire loop is now running 1m down with 50 % speed.**